



Premier European Freight Cars

PLEASE READ BEFORE USE AND SAVE
www.mthtrains.com

Set Up - European Fine Scale Coupler

To apply the European fine scale couplers follow the instructions below.

1) To apply the European fine scale coupler you will first need to remove the coupler that is currently installed on your car. The 3-Rail versions come equipped with knuckle couplers and 2-rail versions come equipped with NEM 365/362 coupler assemblies.

a) To remove the knuckle coupler simply unscrew the 2 screws and remove the coupler.

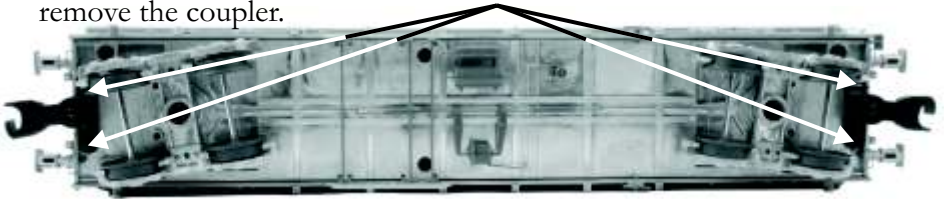

b) To remove the NEM 365/362 coupler assemblies you will first need to remove the truck mounting screw and remove the trucks. Then remove the 4 screws and remove the NEM couper assembly.

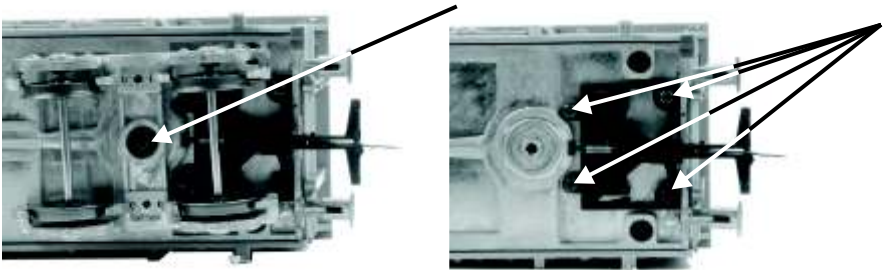

If your car has a fixed truck you will need to remove the wheel and axle set before removing the coupler assembly. To remove the wheel set gently pull outward on the truck sides and lift the wheel set out.

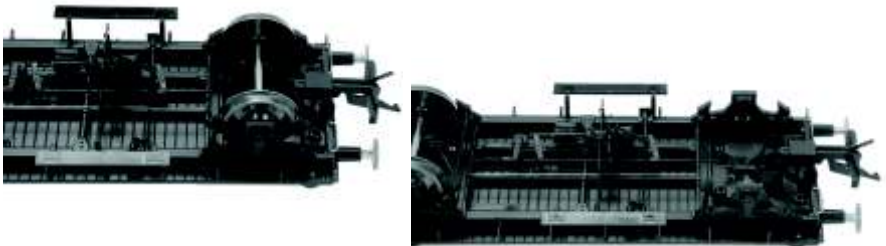

2) Using a screw driver, push out the small detail that plugs the hole where the fine scale coupler will be applied.

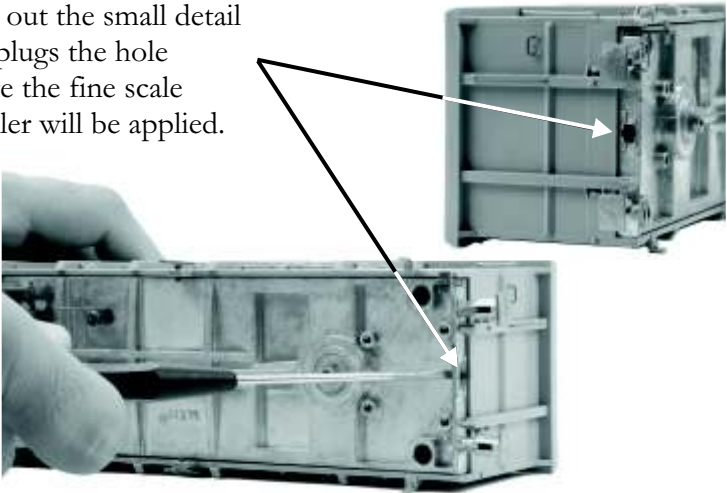

3) Apply the European fine scale coupler by pushing the tap on the hook into the hole.

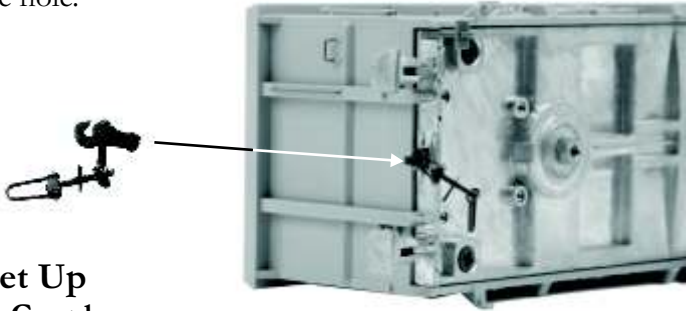

Coupler Set Up Connecting Couplers

To connect the fine scale couplers together use a pair of needle nose pliers and pull the coupler out by the loop. Then connect the loop to the hook on the other car's coupler.

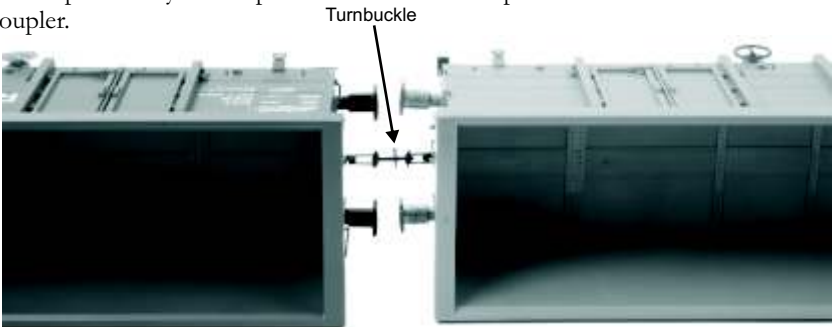

After you connect the couplers together you may want to tighten or loosen the turnbuckle to adjust the space in-between the cars.

Set Up - Truck

Depending on which freight car that you purchased, your car may come with additional parts that may be added to the trucks for a more prototypical look. Please be aware that these parts can only be added when operating the cars with the European fine scale couplers.

To install the additional truck parts please follow the instructions below.

1) First unscrew one of the screws on top of the truck bolster and remove the truck side and wheel sets.

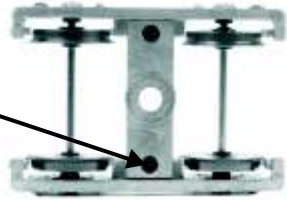

2) Next add the two cross beams to the ends of the truck sides and reassemble the truck. Please note that the bend in the cross beam should face downward.

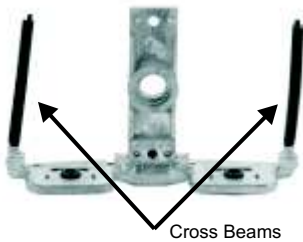

3) Now insert the 4 brake shoe rods into the small holes on the truck sides. You will need to bend them slightly and let them slip into the holes on the other truck side.

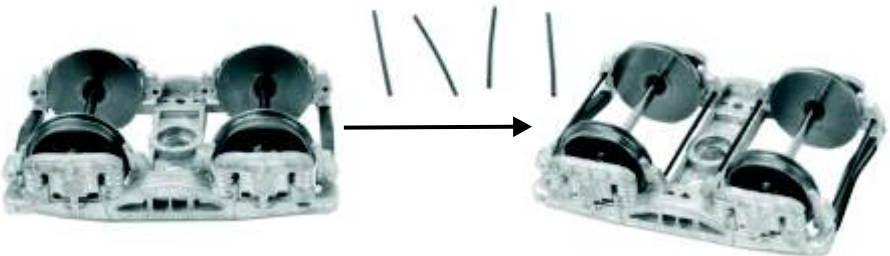

4) Reattach the trucks to the car with the truck mounting screw.



To add the parts to a fixed truck please refer to the instructions below. Please be aware that these parts can also only be added when operating the cars with the European fine scale couplers.

1) First assemble the truck bracket as shown below.



2) Next insert the boss at the bottom of the bracket into the small hole in the base and insert the brake rods into the small holes in the brake shoes..

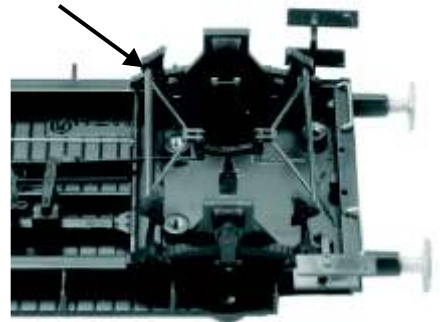
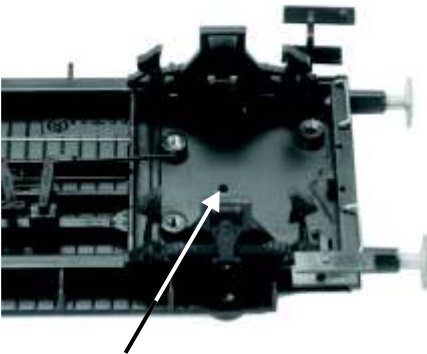

3) Then insert the undercarriage rod into the small hole on the bracket and reassemble the wheel set.

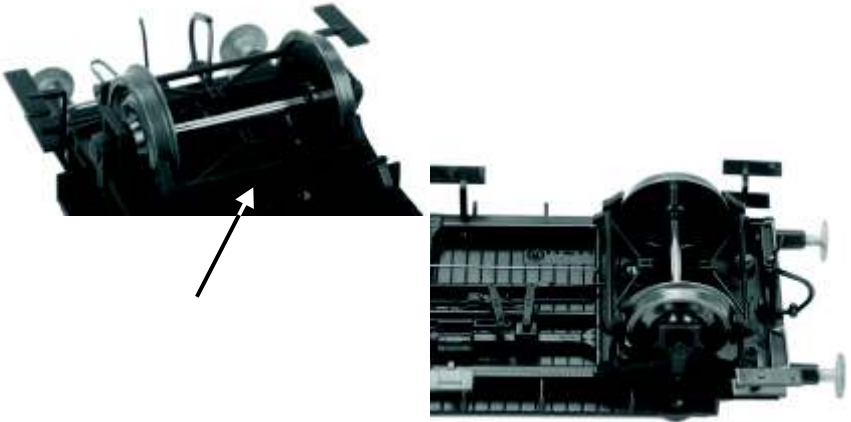

Set Up - Additional Parts

Depending on which freight car that you purchased, your car may come with additional parts that may be added for a more prototypical look. Please be aware that these parts can only be added when operating the cars with the European fine scale couplers.



To apply the details add a drop of glue to the boss and insert it into the small hole on the car's frame.



Brake Hose Detail



Hook Detail

Brake Hose Detail

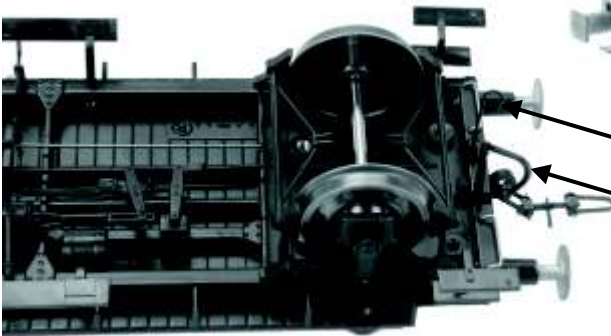

Service & Warranty Information

How to Get Service Under the Terms of the Limited One-Year Warranty

When you suspect an item is defective, please check the operator's manual for standard operation and trouble-shooting techniques that may correct the problem. Additional information may be found on the M.T.H. Website. Should you still require service, follow the instructions below to obtain warranty service.

First, e-mail, write, call or fax a M.T.H. Authorized Service Center (ASC) in your area to obtain Repair Authorization. You can find the list of ASCs on the M.T.H. Website, www.mthtrains.com. Authorized Service Centers are required to make warranty repairs on items sold *only* from that store; all other repairs may-- or may not be done at the store's own discretion. If you did not purchase the item directly from the ASC, you will need to select a National Authorized Service Center (NASC). These centers are compensated by M.T.H. to perform warranty service for any customer whose repair qualifies for warranty service. A list of NASC retailers can be located on the M.T.H. Website or by calling 410-381-2580. Should the warranty no longer apply, you may choose either an ASC or NASC retailer to service your M.T.H. Product. A reasonable service fee will be charged.

CAUTION: Make sure the product is packed in its original factory packaging including its foam and plastic wrapping material to prevent damage to the merchandise. There is no need to return the entire set if only one of the components is in need of repair *unless otherwise instructed by the Service Center*. **The shipment must be prepaid and we recommend that it be insured. A cover letter including your name, address, daytime phone number, e-mail address (if available), Return Authorization number (if required by the service center), a copy of your sales receipt and a full description of the problem must be included to facilitate the repairs. Please include the description regardless of whether you discussed the problem with a service technician when contacting the Service Center for your Return Authorization.**

Please make sure you have followed the instructions carefully before returning any merchandise for service. Authorized M.T.H. Service Centers are independently owned and operated and are not agents or representatives of M.T.H. Electric Trains. M.T.H. assumes no responsibility, financial or otherwise, for material left in their possession, or work done, by privately owned M.T.H. Authorized Service Centers.

If you need assistance at any time email MTH Service at service@mth-railking.com, or call 410 381-2580.

Limited One-Year Warranty

All M.T.H. products purchased from an Authorized M.T.H. Retailer are covered by this warranty. See our Website www.mthtrains.com to identify an M.T.H. Retailer near you.

You can register your warranty online at www.mthtrains.com/warranty.

M.T.H. products are warranted for one year from the date of purchase against defects in material or workmanship, excluding wear items such as light bulbs, pick-up rollers, batteries, smoke unit wicks, and traction tires. We will repair, replace, or credit (at our option) the defective part without charge for the parts or labor, if the item is returned to an M.T.H. Authorized Service Center (ASC) or M.T.H. National Authorized Service Center (NASC) within one year of the original date of purchase. This warranty does not cover damages caused by improper care, handling, or use. Transportation costs incurred by the customer are not covered under this warranty.

Items sent for repair must be accompanied by a return authorization number, a description of the problem, and a **copy of the original sales receipt from an Authorized M.T.H. Train Merchant**, which gives the date of purchase. If you are sending this product to an Authorized Service Center, contact that Center for their return authorization.

This warranty gives you specific legal rights, and you may have other rights that vary from state to state. Specific questions regarding the warranty may be forwarded to M.T.H. Directly.

Service Department:

M.T.H. Electric Trains

7020 Columbia Gateway Drive

Columbia MD 21046-1532

410-381-2580, service@mth-railking.com